

# IR 2400

# EN

**OPERATING MANUAL**  
RADIANT HEATER

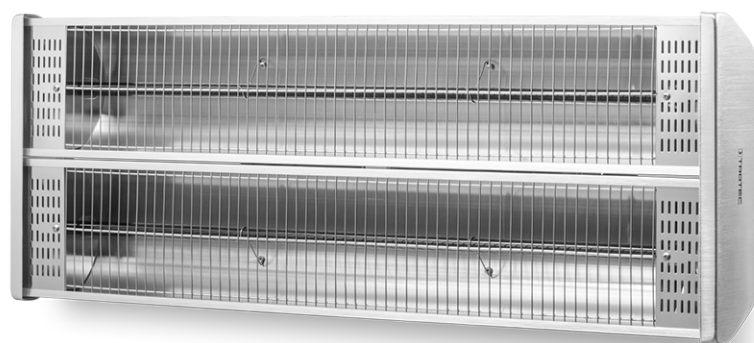

**Table of contents**

Notes regarding the operating manual..... 2

Safety ..... 2

Information about the device..... 5

Transport and storage..... 6

Assembly and start-up..... 6

Operation ..... 9

Errors and faults..... 10

Maintenance ..... 10

Technical annex..... 11

Disposal ..... 11

**Notes regarding the operating manual**

**Symbols**



**Warning of electrical voltage**

This symbol indicates dangers to the life and health of persons due to electrical voltage.



**Warning of hot surface**

This symbol indicates dangers to the life and health of persons due to hot surface.



**Warning**

This signal word indicates a hazard with an average risk level which, if not avoided, can result in serious injury or death.



**Caution**

This signal word indicates a hazard with a low risk level which, if not avoided, can result in minor or moderate injury.

**Note**

This signal word indicates important information (e.g. material damage), but does not indicate hazards.



**Info**

Information marked with this symbol helps you to carry out your tasks quickly and safely.



**Follow the manual**

Information marked with this symbol indicates that the operating manual must be observed.

You can download the current version of the operating manual and the EU declaration of conformity via the following link:



IR 2400



<https://hub.trotec.com/?id=45812>

**Safety**

**Read this manual carefully before starting or using the device. Always store the manual in the immediate vicinity of the device or its site of use.**



**Warning**

**Read all safety warnings and all instructions.**

Failure to follow the warnings and instructions may result in electric shock, fire and/or serious injury.

**Save all warnings and instructions for future reference.**

This appliance can be used by children aged from 8 years and above and persons with reduced physical, sensory or mental capabilities or lack of experience and knowledge if they have been given supervision or instruction concerning use of the appliance in a safe way and understand the hazards involved. Children shall not play with the appliance. Cleaning and user maintenance shall not be made by children without supervision.



**Warning**

Children of less than 3 years should be kept away from the device unless continuously supervised.

Children aged from 3 years and less than 8 years shall only switch on/off the appliance provided that it has been placed or installed in its intended normal operating position and they have been given supervision or instruction concerning use of the appliance in a safe way and understand the hazards involved.

Children aged from 3 years and less than 8 years shall not plug in, regulate and clean the appliance or perform user maintenance.

- Do not use the device in potentially explosive rooms or areas and do not install it there.
- Do not use the device in aggressive atmosphere.
- Let the device dry out after a wet clean. Do not operate it when wet.
- Do not use the device with wet or damp hands.
- Do not expose the device to directly squirting water.

- Never insert any objects or limbs into the device.
- Do not use the device as source of ignition.
- Do not cover the device during operation.
- This appliance is not a toy. Keep away from children and animals. Do not leave the device unattended during operation.
- Check accessories and connection parts for possible damage prior to every use of the device. Do not use any defective devices or device parts.
- Ensure that all electric cables outside of the device are protected from damage (e.g. caused by animals). Never use the device if electric cables or the power connection are damaged!
- The mains connection must correspond to the specifications in the Technical annex.
- Insert the mains plug into a properly fused mains socket.
- Observe the device's power input, cable length and intended use when selecting extensions to the power cable. Completely unroll extension cables. Avoid electrical overload.
- Before carrying out maintenance, care or repair work on the device, remove the mains plug from the mains socket. Hold onto the mains plug while doing so.
- Switch the device off and disconnect the power cable from the mains socket when the device is not in use.
- Do not under any circumstances use the device if you detect damages on the mains plug or power cable. If the power cable is damaged, it must be replaced by the manufacturer, its service agent or similarly qualified persons in order to avoid a hazard. Defective power cables pose a serious health risk!
- When installing the device, observe the minimum distances from walls and other objects as well as the storage and operating conditions according to the technical data (chapter Technical annex).
- Keep a safety distance of at least 1 m between the device's radiator side and all combustible materials such as textiles, curtains, beds and sofas.
- Allow the device to cool down before transport and/or maintenance work.
- The device must not be installed directly beneath a socket.
- The device must not be used with a programming switch, timer, separate remote control system or similar equipment that switches the device on automatically, as this could cause a fire hazard if the heater is covered or positioned incorrectly.
- Do not use the device if it has been dropped or if it shows visible signs of damage.
- Use batteries of type AAA.
- Never charge batteries that cannot be recharged.
- Different types of batteries and new and used batteries must not be used together.
- Insert the batteries into the battery compartment according to the correct polarity.
- Remove discharged batteries from the device. Batteries contain materials hazardous to the environment. Dispose of the batteries according to the national regulations.
- Remove the batteries from the remote control if you will not be using the device for a longer period of time.
- Never short-circuit the supply terminal in the battery compartment!
- Do not swallow batteries! If a battery is swallowed, it can cause severe internal burns within 2 hours! These burns can lead to death!
- If you think batteries might have been swallowed or otherwise entered the body, seek medical attention immediately!
- Keep new and used batteries and an open battery compartment away from children.
- If the battery compartment does not close securely, stop using the product via the remote control.

### Intended use

Use the device for heating surfaces in roofed and non-roofed outdoor areas.

The device is only intended for wall mounting.

Intended use comprises:

- heating surfaces
  - in storage facilities,
  - in construction areas,
  - in containers,
  - in the catering trade,
  - at trade fairs and events,
  - in outdoor areas (e.g. terraces).

### Foreseeable misuse

- The device is not intended for industrial use.
- Do not place any objects, e.g. clothing, on the device.
- Do not use the device for heating in vehicles.
- Do not use this device in the vicinity of fuel, solvents, varnishes or other easily inflammable vapours or in rooms where these substances are stored.
- The device may not be used as a heating device for babies / children or animals.
- Do not install the heating device in immediate proximity to swimming pools!
- The device may not be exposed to moisture or weather effects (rain, sunlight).
- Any use other than the intended use is regarded as a reasonably foreseeable misuse.

Any unauthorised changes, modifications or alterations to the device are forbidden.

### Personnel qualifications

People who use this device must:

- be aware of the dangers that occur when working with electric devices in damp areas.
- have read and understood the operating manual, especially the Safety chapter.

Maintenance tasks which require the housing to be opened must only be carried out by specialist electrical companies or by Trotec.

### Symbols on the device

Symbols	Meaning
	This symbol located on the device indicates that it is prohibited to place objects (such as towels, clothes etc.) above or directly in front of the device. In order to avoid overheating and fire hazards, the heater must not be covered.

### Residual risks



#### Warning of electrical voltage

Work on the electrical components must only be carried out by an authorised specialist company!



#### Warning of electrical voltage

Before any work on the device, remove the mains plug from the mains socket!  
Do not touch the mains plug with wet or damp hands.  
Hold onto the mains plug while pulling the power cable out of the mains socket.



#### Warning of electrical voltage

Risk of electric shock!  
Risk of an electric shock if the heating device comes into contact with water in swimming pools!  
Do not install the heating device in immediate proximity to swimming pools!



#### Warning of hot surface

Parts of this appliance can become very hot and cause burns. Particular attention is to be paid when there are children or vulnerable persons present!



#### Warning

Dangers can occur at the device when it is used by untrained people in an unprofessional or improper way! Observe the personnel qualifications!



#### Warning

The device is not a toy and does not belong in the hands of children.



#### Warning

Risk of suffocation!  
Do not leave the packaging lying around. Children may use it as a dangerous toy.



#### Warning

Improper installation entails a risk of fire.  
Do not place the device on combustible ground.  
Do not place the device on high-pile carpets.



#### Warning

Risk of injury due to infrared radiation!  
Do not stay in the device's immediate vicinity for too long. Do not look directly into the device for too long. Observe the minimum distances.



#### Warning

In order to avoid overheating and fire hazards, the device must not be covered!



#### Warning

Coarse dirt particles on the heating rods can cause the device to overheat. Fire hazard!  
Remove coarse dirt particles from the heating rods according to the Maintenance chapter before switching on the device.

### Behaviour in the event of an emergency

1. Switch the device off.
2. In an emergency, disconnect the device from the mains feed-in: Hold onto the mains plug while pulling the power cable out of the mains socket.
3. Do not reconnect a defective device to the mains.

## Information about the device

### Device description

The device is used to quickly generate instant heat.

The device is based on the functional principle of heat generation by infrared radiation, which is generated by a halogen heating element. The infrared radiation is passed on to the surrounding surfaces as heat radiation. Persons or objects are heated directly.

Both heating levels can be selected on the device or by using the remote control.

- suitable for roofed and non-roofed outdoor use
- IP55 type of protection – splash- and water-jet-proof
- silent operation
- no dust circulation (suitable for allergy sufferers)
- Adjustable angle

### Device depiction

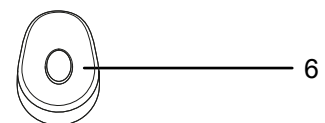
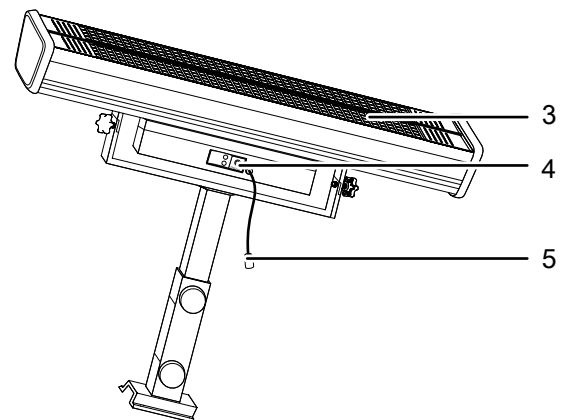
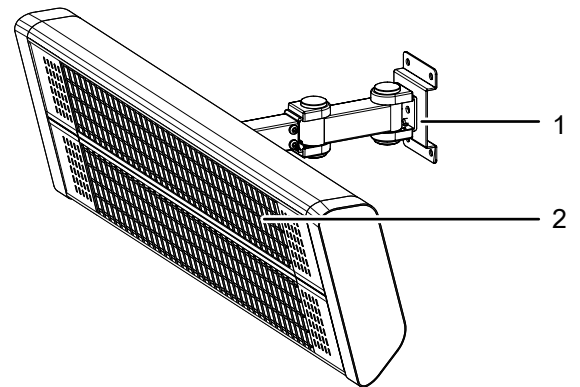

No.	Designation
1	Wall holder
2	Grille
3	Heating element
4	Control panel
5	Pull switch
6	Remote control

## Transport and storage

### Note

If you store or transport the device improperly, the device may be damaged.

Note the information regarding transport and storage of the device.

## Transport

Before transporting the device, observe the following:

- Switch the device off.
- Hold onto the mains plug while pulling the power cable out of the mains socket.
- Do not use the power cable to drag the device.
- Allow the device to cool down sufficiently.

## Storage

Before storing the device, proceed as follows:

- Hold onto the mains plug while pulling the power cable out of the mains socket.
- Allow the device to cool down sufficiently.

When the device is not being used, observe the following storage conditions:

- Store the device in a dry location and protected from frost and heat.
- Store the device in an upright position where it is protected from dust and direct sunlight.
- If required, use a cover to protect the device from invasive dust.
- Place no further devices or objects on top of the device to prevent it from being damaged.
- Remove batteries from the remote control.

## Assembly and start-up

### Scope of delivery

- 1 x Device
- 1 x Wall holder
- 1 x Holder
- 4 x Screw for wall holder
- 4 x Screw for holder
- 1 x M6 wrench
- 1 x Remote control
- 1 x Manual

## Unpacking the device

1. Open the cardboard box and take the device out.
2. Completely remove the packaging.
3. Remove the transport protection (7) from the grille of the radiant heater.

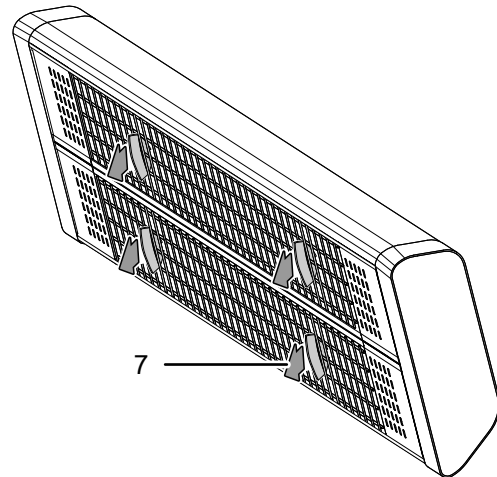

4. Fully unwind the power cable. Make sure that the power cable is not damaged and that you do not damage it during unwinding.

## Assembly



### Warning of electrical voltage

Risk of injury due to incorrect assembly!

Local or national regulations may apply for installation. We recommend to have the installation carried out by a qualified electrician.



### Warning

Risk of fire due to improper installation!

There is a risk of fire if the required minimum distances are not observed.

Observe the "Installation" section in the "Assembly and start-up" chapter and the technical data in the "Technical annex" chapter.



## Mounting the wall holder

- ✓ Use tools suitable for the intended task.
- 1. Screw the holder to the device using the four screws supplied.
  - ⇒ The wall bracket can be rotated downwards between 30° and 45°.

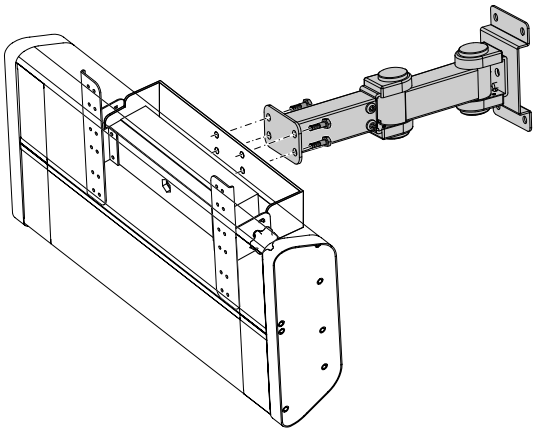

## Installation

When installing the device, observe the minimum distances from walls and other objects as described in the Technical data chapter.

- Install the device at a distance of at least 180 cm from the floor.
- Do not install the device directly behind a door.
- Never install the device in a way that it radiates directly onto walls or other objects. Observe the minimum distances from walls or other objects according to the Technical data chapter.
- Only install the device in a horizontal position.
- Please note that the minimum distance to the front also applies to objects mounted on the ceiling, e.g. fans, lamps or sprinkler systems.

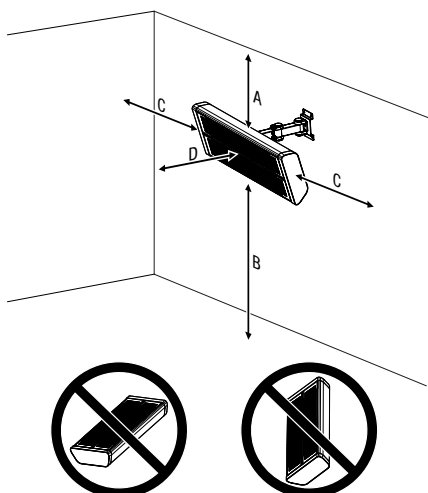

The following is required for installation:

- a pencil for marking the drill holes
- a tape measure for determining the distances
- a suitable drill
- a drill suitable for the wall material,  $\varnothing$  6 mm.
- a wrench SW 10 mm
- a spirit level

1. Mark the drill holes on the wall according to the following pattern:

⇒ Please note that the device must be mounted in horizontal position. Use a spirit level for this purpose.

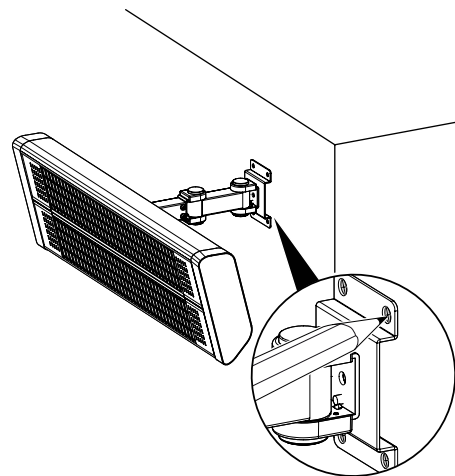

2. Drill the holes into the wall at the marked positions.
3. Insert the wedge bolts included in the scope of delivery into the holes without the nuts and washers.

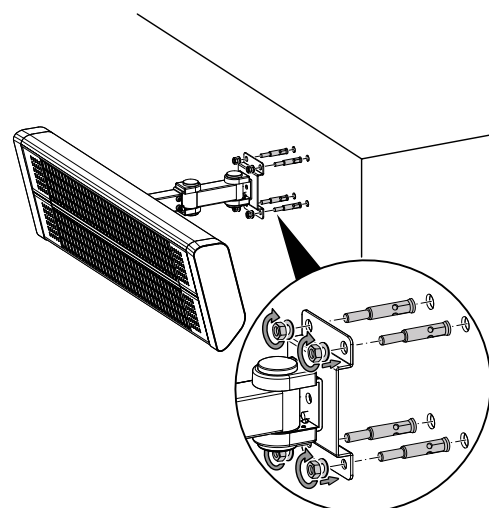

4. Position the mounting brackets of the device over the threads of the wedge bolts and secure the mounting brackets with the washers and the nuts.
5. Use a wrench to tighten the nuts firmly.
6. Make sure that the device is attached securely.

7. Loosen the star screws (8) on both sides of the device and tilt the device to the desired angle. Observe the different inclination angles.
- ⇒ When mounting the device on a wall, only align the device downwards at an angle of 30° to 45°.

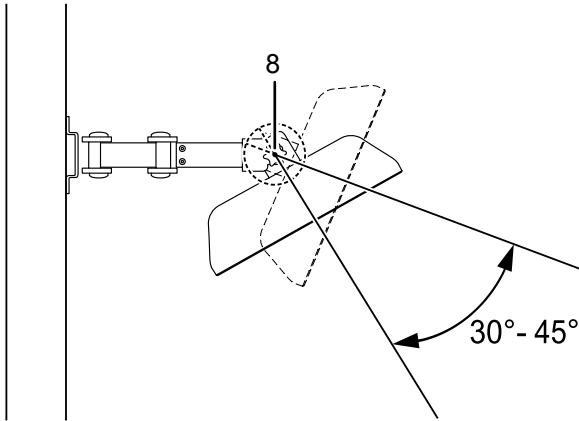

8. Once the device is at the desired inclination angle, retighten the star screw (8) on both sides of the device.

### Start-up



#### Info

Odours might arise upon initial start-up or after a longer period of non-use.

- Before restarting the device, check the condition of the power cable. If there are doubts as to the sound condition, contact the customer service.
- Do not create tripping hazards when laying the power cable or other electric cables, especially when positioning the device in the middle of the room. Use cable bridges.
- Make sure that extension cables are completely unrolled.
- Make sure that there are no curtains or similar objects in the immediate vicinity.

### Inserting batteries into the remote control



#### Warning of electrical voltage

Do not touch the battery compartment with wet or damp hands.

Please proceed as follows to insert or exchange the batteries:

1. Press the upper part (11) on the back of the remote control and pull the battery cover off the remote control.
2. Insert two batteries into the battery compartment according to the correct polarity.
3. Slide the battery cover back onto the remote control.

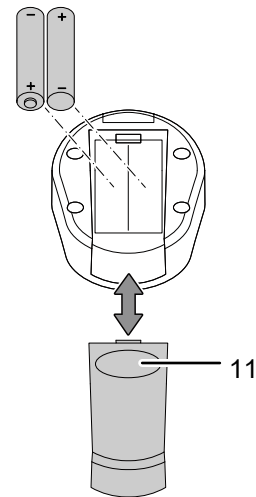

### Connecting the power cable

- Insert the mains plug into a properly fused mains socket.



## Operation

### Operating elements

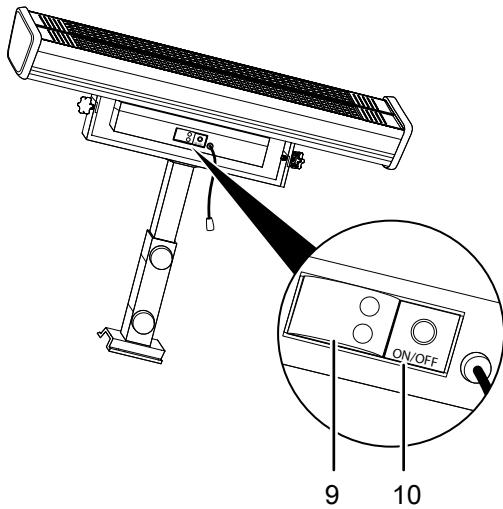

### Remote control

All settings of the device can also be made using the remote control included in the scope of delivery.

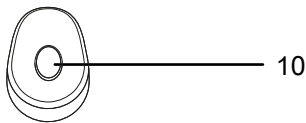

No.	Designation	Meaning
9	Heating level LEDs	One LED will be illuminated if the device is in standby mode Two LEDs will be illuminated if heating level 1 or heating level 2 is activated
10	On/off switch	For switching the device on or off Selecting the 1200 W or 2400 W heating level

### Switching the device on

Once you have completely installed the device as described in the chapter Assembly and start-up, you can switch it on.

- ✓ Plug the mains plug into a sufficiently fused socket.
- 1. Pull the pull switch (5).
  - ⇒ The device is now in standby mode.
  - ⇒ One of the heating level LEDs (9) is illuminated.
- 2. Press the on/off switch (10).
  - ⇒ If you press the on/off switch (10) once, the 1200 W heating level is activated.
  - ⇒ If you press the on/off switch (10) twice, the 2400 W heating level is activated.
  - ⇒ Both heating level LEDs (9) are illuminated.
- 3. If you press the on/off switch (10) three times, the device switches to standby mode.
  - ⇒ One of the heating level LEDs (9) is illuminated. The other LED goes out.

### Shutdown



#### Warning of electrical voltage

Do not touch the mains plug with wet or damp hands.

- Press the on/off switch (10) to activate the standby mode.
- Pull the pull switch (5) to switch off the device.
- Allow the device to cool down completely.
- Hold onto the mains plug while pulling the power cable out of the mains socket.
- Clean the device according to the Maintenance chapter.
- Store the device according to the Transport and storage chapter.

## Errors and faults



### Warning of electrical voltage

**Tasks which require the device to be opened must only be carried out by authorised specialist companies or by Trotec.**

The device has been checked for proper functioning several times during production. If malfunctions occur nonetheless, check the device according to the following list.

#### The device does not start:

- Check the power connection.
- Check the power cable and mains plug for damage. If you notice damages, do not try to take the device back into operation.  
If the supply cord is damaged, it must be replaced by the manufacturer, its service agent or similarly qualified persons in order to avoid a hazard.
- Check the on-site fusing.
- Wait for 10 minutes before restarting the device. If the device is not starting, have the electrics checked by a specialist company or by Trotec.

#### The device does not emit heat:

- The heating element may be defective. If the heating element is defective, have it replaced by a specialist electrical company.
- Check whether the heating level LEDs (9) are illuminated. If neither LED is illuminated, the device is switched off. Switch the device on by pulling the pull switch (5), then press the on/off switch (10).

#### RCD or another fuse trips:

- Check the fuse. Switch off any other devices to reduce the load on the line.
- Contact a specialist electrical company.

#### The device slightly vibrates during switch-on and then stops vibrating:

- Slight vibrations during switch-on are a normal process. No measures are required.

#### The device does not respond to the infrared remote control:

- Check whether the distance between remote control and device is too large and reduce it if necessary.
- Make sure there are no obstacles, such as furniture or walls, between the device and the remote control. Ensure visual contact between device and remote control.
- Check the charging status of the batteries and change them if required.
- If the batteries have just been changed, check them for correct polarity.

### Note

Wait for at least 3 minutes after maintenance and repair work. Only then switch the device back on.

#### The device still does not operate correctly after these checks:

Please contact the customer service. If necessary, bring the device to an authorised specialist electrical company or to Trotec for repair.

## Maintenance

### Activities required before starting maintenance



#### Warning of electrical voltage

Do not touch the mains plug with wet or damp hands.

- Switch the device off.
- Hold onto the mains plug while pulling the power cable out of the mains socket.
- Allow the device to cool down completely.



#### Warning of electrical voltage

**Tasks which require the device to be opened must only be carried out by authorised specialist companies or by Trotec.**

### Cleaning the device



#### Warning of electrical voltage

Never immerse the device in water!



#### Warning of hot surface

Do not touch the reflector or the heating rods with bare hands.

Clean the device with a soft, damp and lint-free cloth. Ensure that no moisture enters the housing. Protect electrical components from moisture. Do not use any aggressive cleaning agents such as cleaning sprays, solvents, alcohol-based or abrasive cleaners to dampen the cloth.

Wipe the housing dry after cleaning.

Dirt on the heating rods should be removed with a long brush with soft bristles.

## Technical annex

### Technical data

Parameter	Value
Model	IR 2400
Heating capacity	2400 W
Mains connection	220-240 V ~ 50-60 Hz
Plug type	CEE 7/7
Cable length	180 cm
Type of protection	IP55
Dimensions (length x width x height)	260 x 710 x 75 mm
Minimum distance to walls and other objects:	top (A): 50 cm bottom (B): 180 cm sides (C): 50 cm front (D): 50 cm
Weight (kg)	4 kg
Remote control batteries	AAA/1.5 V

## Disposal



The icon with the crossed-out waste bin on waste electrical or electronic equipment stipulates that this equipment must not be disposed of with the household waste at the end of its life. You will find collection points for free return of waste electrical and electronic equipment in your vicinity. The addresses can be obtained from your municipality or local administration. You can also find out about other return options that apply for many EU countries on the website <https://hub.trotec.com/?id=45090>. Otherwise, please contact an official recycling centre for electronic and electrical equipment authorised for your country.

The separate collection of waste electrical and electronic equipment aims to enable the re-use, recycling and other forms of recovery of waste equipment as well as to prevent negative effects for the environment and human health caused by the disposal of hazardous substances potentially contained in the equipment.



In the European Union, batteries and accumulators must not be treated as domestic waste, but must be disposed of professionally in accordance with Directive 2006/66/EC of the European Parliament and of the Council of 6 September 2006 on batteries and accumulators. Please dispose of batteries and accumulators according to the relevant legal requirements.

### Only for United Kingdom

According to Waste Electrical and Electronic Equipment Regulations 2013 (2013/3113) and the Waste Batteries and Accumulators Regulations 2009 (2009/890), power tools that are no longer usable must be collected separately and disposed of in an environmentally friendly manner.

Trotec GmbH

Grebener Str. 7  
D-52525 Heinsberg

☎ +49 2452 962-400

☎ +49 2452 962-200

✉ [info@trotec.com](mailto:info@trotec.com)

[www.trotec.com](http://www.trotec.com)