

VC 10-20 V

EN

ORIGINAL INSTRUCTIONS
HAND-HELD VACUUM CLEANER



 TROTEC

Table of contents

Notes regarding the operating manual..... 2

Safety 2

Information about the device..... 6

Transport and storage..... 7

Start-up..... 8

Operation 9

Available accessories..... 10

Errors and faults..... 10

Maintenance 11

Disposal 13

Notes regarding the operating manual

Symbols



Warning of electrical voltage

This symbol indicates dangers to the life and health of persons due to electrical voltage.



Warning of explosive substances

This symbol indicates dangers to the life and health of persons due to potentially explosive substances.



Warning

This signal word indicates a hazard with an average risk level which, if not avoided, can result in serious injury or death.



Caution

This signal word indicates a hazard with a low risk level which, if not avoided, can result in minor or moderate injury.

Note

This signal word indicates important information (e.g. material damage), but does not indicate hazards.



Info

Information marked with this symbol helps you to carry out your tasks quickly and safely.



Follow the manual

Information marked with this symbol indicates that the operating manual must be observed.

You can download the current version of the operating manual and the EU declaration of conformity via the following link:

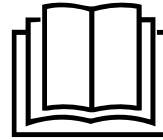

VC 10-20V



<https://hub.trotec.com/?id=45535>

Safety

Read this manual carefully before starting or using the device. Always store the manual in the immediate vicinity of the device or its site of use.



Warning

Read all safety warnings and all instructions.

Failure to follow the warnings and instructions may result in electric shock, fire and/or serious injury.

Save all warnings and instructions for future reference.

This appliance can be used by children aged from 8 years and above and persons with reduced physical, sensory or mental capabilities or lack of experience and knowledge if they have been given supervision or instruction concerning use of the appliance in a safe way and understand the hazards involved.

Children shall not play with the appliance. Cleaning and user maintenance shall not be made by children without supervision.

- Do not open the device housing or the power adapter. There is danger of a short circuit.
- Keep device and power adapter away from open fire and hot surfaces and do not store or operate them in their vicinity.
- Do not pull the power adapter out of the socket by the connection cable, always hold on to the power adapter itself.
- Do not leave the device running unattended.
- Insert the mains plug into a properly fused mains socket.
- Allow the device to cool down before transport and/or maintenance work.
- Do not use the device in aggressive atmosphere.
- Do not use the device in potentially explosive rooms or areas and do not install it there.
- Do not use the device with wet or damp hands.

- Do not use this device near bathtubs, shower trays, swimming pools or other water containers. Risk of electric shock!
- Do not expose the device to directly squirting water.
- Never insert any objects or limbs into the device.
- Do not operate the device in the vicinity of eyes or ears. Nozzles and pipe ends must never get too close to eyes or ears.
- Let the device dry out after a wet clean. Do not operate it when wet.
- Do not under any circumstances use the device if you detect damages on the mains plug or power cable. If the power cable is damaged, it must be replaced by the manufacturer, its service agent or similarly qualified persons in order to avoid a hazard. Defective power cables pose a serious health risk!
- Do not sit on the device.
- Before carrying out maintenance, care or repair work on the device, remove the mains plug from the mains socket. Hold onto the mains plug while doing so.
- The power connection must correspond to the specifications in the Technical annex.
- Check accessories and connection parts for possible damage prior to every use of the device. Do not use any defective devices or device parts.
- Make sure that the suction side is kept free of dirt and loose objects.
- Make sure that the suction inlet and air outlets are not obstructed. A blocked air circuit can lead to overheating and device damage.
- Do not use the device while it is connected to the power adapter.
- Clean the dust filter, the filter bag and the collection container on a regular basis to prevent a motor overload.
- Do not exchange any accessories during operation.
- Do not use the hand-held vacuum cleaner without inserted dust filter.



General Battery Pack / Charger Safety Warnings

- **This charger can be used by children aged from 8 years and above and persons with reduced physical, sensory or mental capabilities or lack of experience and knowledge if they have been given supervision or instruction concerning use of the appliance in a safe way and understand the hazards involved. Children shall not play with the appliance.** Cleaning and user maintenance shall not be made by children without supervision.
- **Never insert non-rechargeable batteries into the charger.** A charger that is suitable for one type of battery pack may create a risk of fire and explosion, when used with another battery pack or non-rechargeable batteries.
- Only charge the Li-Ion battery "Multiflex 20 – 2.0 DC" (capacity of 2.0 Ah = 5 battery cells) with the charger "Multiflex 20 – 2.0 AC". The battery voltage must match the battery charging voltage of the charger.
- **Use products only with the specifically designated battery packs.** Use of any other battery packs may create a risk of injury and fire.
- **When battery pack is not in use, keep it away from other metal objects, like paper clips, coins, keys, nails, screws or other small metal objects, that can make a connection from one terminal to another.** Shorting the battery terminals together may cause burns or a fire.
- **Recharge only with the charger specified by the manufacturer.** A charger that is suitable for one type of battery pack may create a risk of fire when used with another battery pack.
- **Do not charge other battery packs.** The charger is only suitable for use with the supplied battery pack and with the voltages specified in the technical data. Otherwise, there is a risk of fire and explosion.
- **Under abusive conditions, liquid may be ejected from the battery;** avoid contact. If contact accidentally occurs, flush with water. If liquid contacts eyes, additionally seek medical help. Liquid ejected from the battery may cause irritation or burns.
- **In case of damage and improper use of the battery, vapours may be emitted.** Provide for fresh air and seek medical help in case of complaints. The vapours can irritate the respiratory system.
- **Do not open the battery.** There is danger of a short circuit.
- **Do not short-circuit the battery.** There is danger of explosion.
- **Batteries must not be exposed to mechanical impacts.**

- **Protect electrical parts against moisture. To prevent an electric shock, never immerse them in water or other liquids during cleaning or operation.** Never hold the charger under running water. Please observe the instructions for cleaning and maintenance.
- **The charger is only suited for indoor use.**
- **Keep the charger clean.** Contamination entails a risk of electric shock.
- **Do not operate the charger on highly combustible ground (e.g. paper, textiles etc.) or in an inflammable environment.** The heat generated by the charger during charging entails a risk of fire.
- **Only use the charger for charging the battery.** The charger must not be used as power supply for the power tool.

Safety signs and labels on the battery and the charger

Note

Do not remove any safety signs, stickers or labels from the device. Keep all safety signs, stickers and labels in legible condition.

The following safety signs and labels are attached to the battery:



Warning of explosion risk!

These symbols indicate the following:



Do not expose the battery pack or tool to fire or excessive temperature! Do not let the battery come into contact with water or fire! Avoid direct sunlight and moisture. There is a risk of explosion!

Never charge the battery at ambient temperatures below 10 °C or above 40 °C. Charging improperly or at temperatures outside the specified range may damage the battery and increase the risk of fire.



Observe the correct disposal of the battery!

This symbol indicates the following:

Ensure that the battery is disposed of correctly and never dispose of it in waste water or public waters. The battery contains irritating, caustic and toxic substances that pose significant risks to people and the environment.

The following safety signs and labels are attached to the charger:



This symbol indicates the following:
Read the instructions or operating manual before charging the battery.



This symbol indicates the following:
Only use the charger for charging the battery in dry interior spaces. Do not charge the device outdoors.

Intended use

Only use the device to vacuum dry or wet surfaces, dry or wet material or small amounts of liquids in the household or in the car whilst adhering to the technical data.

We recommend using the device with original Trotec accessories.

Foreseeable misuse

The device must only be used as intended. Any other use possibly exceeding the intended purpose is considered to be improper use. The user/operator shall be liable for any consequential damages or injuries resulting from improper use, not the manufacturer. Please bear in mind that this device is not designed for commercial and industrial applications or for use in craft enterprises. We do not accept any liability if the device is used in business, craft or industrial enterprises as well as for similar applications.

Do not use this device for vacuuming on people or animals.

The device must not be used with a damaged or without an inserted dust filter.

The device is not intended for vacuuming the following materials:

- lit matches
- ember
- cigarette stubs
- large or sharp objects or glass splinters
- stone dust
- plaster
- cement or similar particles
- combustible and/or aggressive materials or liquids
- harmful substances

The device may not be used in potentially explosive atmospheres, when wet or very humid.

Any other use than the one described in the chapter "Intended use" is regarded as reasonably foreseeable misuse.

Personnel qualifications

People who use this device must:

- be aware of the dangers that occur when working with electric devices in damp areas.
- have read and understood the operating manual, especially the Safety chapter.

Residual risks



Warning of electrical voltage

Electric shock from insufficient insulation.
Check the device for damages and proper functioning before each use.
If you notice damages, no longer use the device.
Do not use the device when the device or your hands are damp or wet!



Warning of electrical voltage

Work on the electrical components must only be carried out by an authorised specialist company!



Warning of electrical voltage

There is a risk of a short-circuit due to liquids penetrating the housing!
Do not immerse the device and the accessories in water. Make sure that no water or other liquids can enter the housing.



Warning of explosive substances

Do not expose the battery to temperatures above 45 °C! Do not let the battery come into contact with water or fire! Avoid direct sunlight and moisture.
There is a risk of explosion!



Warning

Dangers can occur at the device when it is used by untrained people in an unprofessional or improper way!
Observe the personnel qualifications!



Warning

The device is not a toy and does not belong in the hands of children.



Warning

Risk of suffocation!
Do not leave the packaging lying around. Children may use it as a dangerous toy.



Caution

Keep a sufficient distance from heat sources.

Note

If you store or transport the device improperly, the device may be damaged.
Note the information regarding transport and storage of the device.

Information about the device

Device description

The device VC 10-20V is suited for the vacuum-cleaning of dry or wet surfaces, for vacuuming dry or wet material or small amounts of liquids in the household or in the car.

The device is equipped with a pre-installed filter bag, dust filter and collection container.

An additional crevice nozzle permits the convenient vacuum-cleaning of corners, joints and narrow gaps.

The additional brush nozzle is suited for vacuuming fittings and removing stubborn dirt.

Device depiction

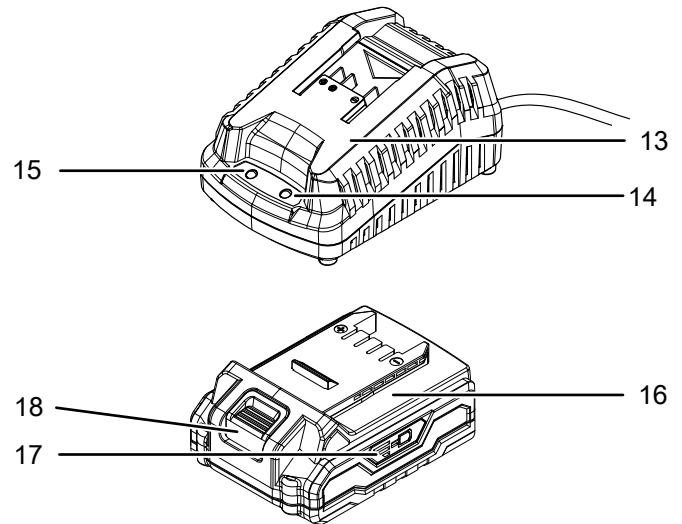
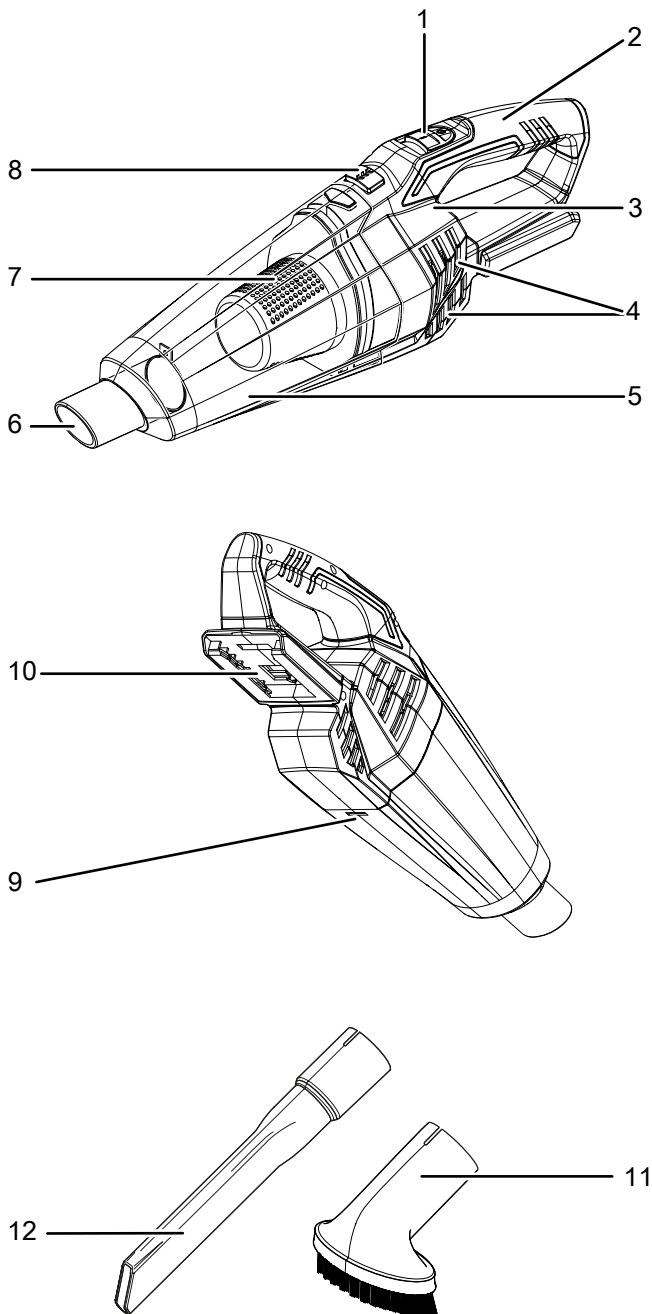



No.	Designation
1	On/off switch
2	Handle
3	Motor housing
4	Exhaust air slots
5	Collection container
6	Suction opening / suction nozzle retainer
7	Dust filter
8	Release button
9	Recess
10	Battery holder
11	Brush nozzle
12	Crevice nozzle
13	Quick charger
14	Red battery LED (battery charging)
15	Green battery LED (quick charger ready for operation)
16	Battery
17	Battery level indication
18	Release button

Scope of delivery

- 1 x Hand-held vacuum cleaner
- 1 x Dust filter
- 1 x Charger
- 1 x Rechargeable battery
- 1 x Crevice nozzle
- 1 x Brush nozzle
- 1 x Manual

Technical data

Parameter	Value
Model	VC 10-20V
Power input	65 W
Max. capacity of the dust container for: Dry dirt	400 ml
Max. runtime	18 minutes
Weight	1.3 kg
Dimensions (length x width x height)	24.5 x 8.5 x 20 cm
Battery	Multiflex 20 – 2.0 DC
Type	Li-ion
Nominal voltage	20 V ---
Rechargeable cells	5
Capacity	40 Wh
Charger	Multiflex 20 – 2.0 AC
Input	
Nominal voltage	230 – 240 V / 50 Hz
Power input	65 W
Output	
Nominal voltage	21.5 V ---
Charging current	2.4 A
Fusing 	3.15 A (slow-blowing)
Charging time	1 h
Protection class	II / 

Transport and storage

Note

If you store or transport the device improperly, the device may be damaged.

Note the information regarding transport and storage of the device.

Transport

Before transporting the device, observe the following:

- Switch off the device.
- Hold onto the mains plug while pulling the power cable of the charger out of the mains socket.
- Allow the device to cool down.
- Remove the battery from the device.

The supplied Li-ion batteries are subjects to the requirements of dangerous goods legislation.

Observe the following when transporting or shipping Li-ion batteries:

- The user may transport the batteries by road without any additional requirements.
- If transport is carried out by third parties (e.g. air transport or forwarding company), special requirements as to packaging and labelling must be observed. This includes consulting a dangerous goods specialist when preparing the package.
 - Only ship batteries if their housing is undamaged.
 - Mask open terminals with tape and pack the battery in a way that it cannot move inside the packaging.
 - Please also observe any other national regulations.

Storage

Before storing the device, observe the following:

- Switch off the device.
- Hold onto the mains plug while pulling the power cable of the charger out of the mains socket.
- Allow the device to cool down.
- Never store the device in a way that it could fall into a bathtub or sink.
- Remove the battery from the device.
- Clean the device as described in the Maintenance chapter.
- Do not store Li-ion batteries which are completely discharged. Storing discharged batteries can lead to a deep discharge and thus damage the battery.

When the device is not being used, observe the following storage conditions:

- Dry and protected from frost and heat
- Ambient temperature below 45 °C
- protected from dust and direct sunlight

Start-up

Unpacking the device

- Take the device and the accessories out of the packaging.
- Check the contents of the packaging for completeness and look for damages.



Warning of electrical voltage

Electric shock from insufficient insulation.
Check the device for damages and proper functioning before each use.
If you notice damages, no longer use the device.
Do not use the device when the device or your hands are damp or wet!



Warning

Risk of suffocation!
Do not leave the packaging lying around. Children may use it as a dangerous toy.

Connecting motor housing and collection container

Before start-up, the motor housing (3) needs to be connected to the collection container (5). To do so, please proceed as follows:

1. Fit the collection container (5) onto the motor housing (3) in a way that the recess (9) at the bottom of the collection container is seated on the tongue beneath the motor housing.
2. Slide the collection container (5) onto the motor housing (3) until the release button (8) snaps into place.

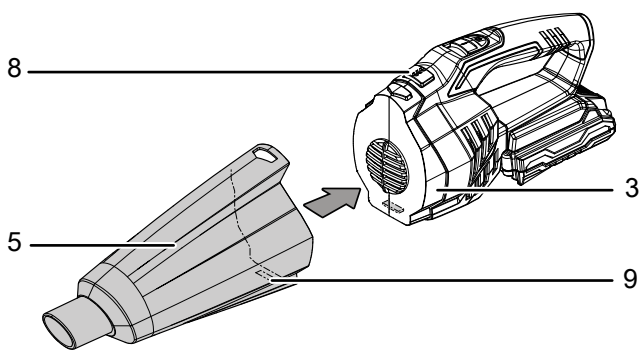

3. Check whether the collection container (5) is firmly seated on the motor housing (3).
 - ⇒ Collection container (5) and motor housing (3) are connected.
- Dispose of the packaging material according to the national regulations.

Charging the battery

Note

The battery can be damaged in case of improper charging.
Remove the charger's mains plug before inserting or removing the battery.
Never charge the battery at ambient temperatures below 10 °C or above 40 °C.

The battery is partially charged upon delivery to avoid damage to the battery caused by a deep discharge.

Prior to initial start-up and when the battery is low (only the red LED in the battery level indication (17) is illuminated), the battery should be charged. To do so, please proceed as follows:

1. Slide the battery (16) onto the quick charger (13) as depicted until the battery locks in place.

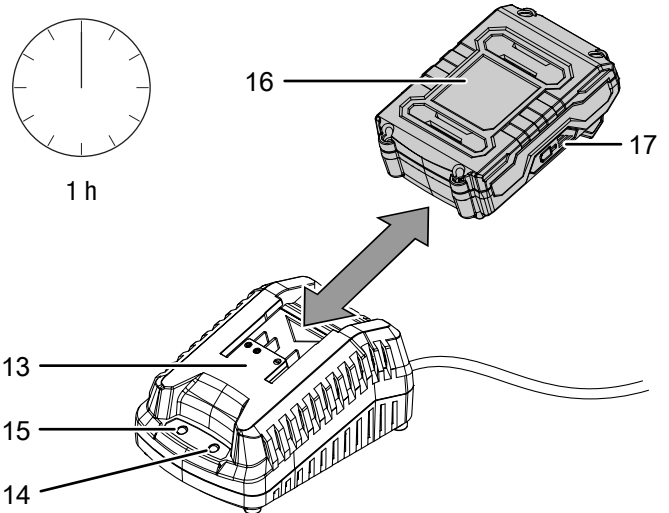

2. Insert the mains plug of the quick charger (13) into a properly fused mains socket.
 - ⇒ The red battery LED (14) lights up.
 - ⇒ Charging requires approx. one hour.
3. Wait until the red battery LED (14) goes off and the green battery LED (15) lights up.
 - ⇒ The battery (16) is fully charged.
4. Hold onto the mains plug while pulling the power cable of the quick charger (13) out of the mains socket.
 - ⇒ The battery (16) and the quick charger (13) may have become warm during charging.
Allow the battery (16) to cool down to room temperature.
5. Take the battery (16) out of the quick charger (13) by pressing and holding the release button (18) and pulling the battery (16) off the quick charger (13).



Info

The device cannot be started when the charger is connected.

Inserting the battery

1. Slide the battery (16) onto the device until it locks in place.

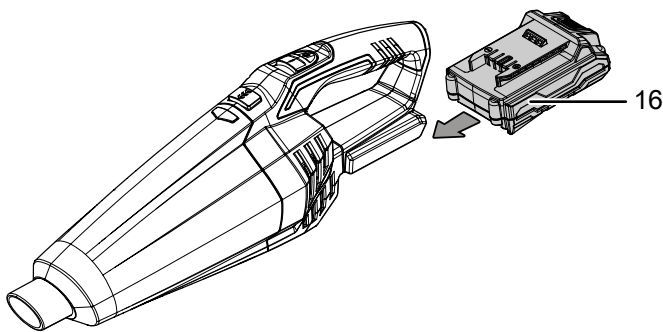

Removing the battery

1. Detach the battery (16) from the device by pressing and holding the unlocking button (18, I.) and pulling the battery off the device (II.).

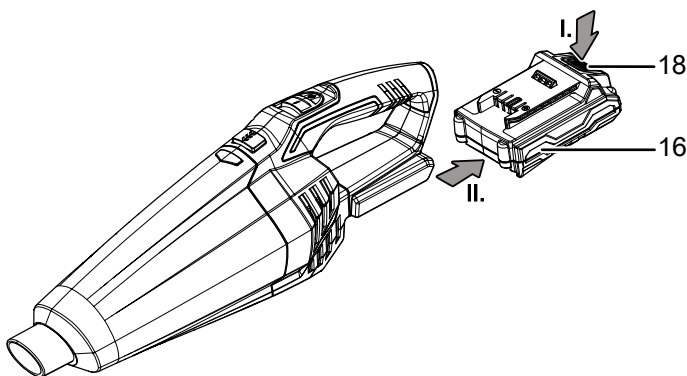

2. If required, charge the battery (16) as described in the section *Charging the battery*.

Checking the battery charging status

The battery comes with an integrated battery level indication. The battery status is displayed as follows by the three LEDs of the battery level indication (17):

LED colour	Meaning
Green – Orange – Red	maximum charge / power
Orange – Red	medium charge / power
Red	weak charge – recharge the battery.

1. Press on the battery icon (19) on the battery (16).
⇒ You can read the battery status from the battery level indication (17).

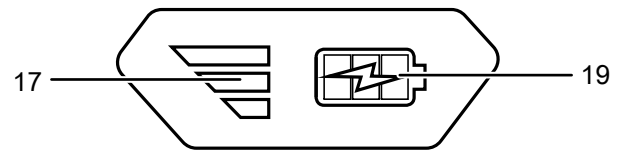

Using crevice nozzle and brush nozzle

The device can be equipped with one of the supplied nozzles: a crevice nozzle and a brush nozzle. To do so, please proceed as follows:

- ✓ The device is switched off.
1. Insert the connection end of the desired nozzle into the suction opening / suction nozzle retainer (6) of the device.
⇒ The device may now be used with the connected nozzle.

Operation

Switching the device on and off

Switching the device on

1. Slide the on/off switch (1) forward to I.

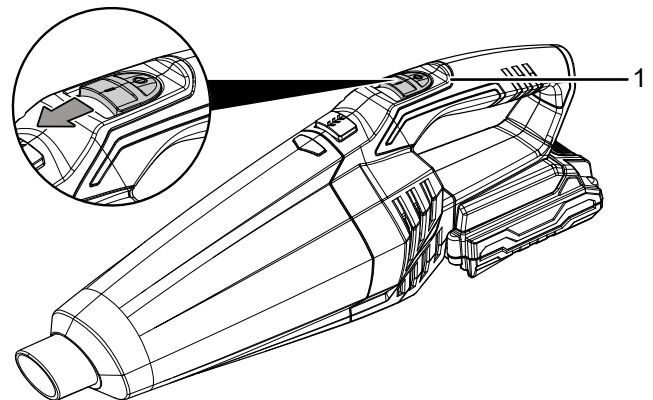

- ⇒ The device is switched on and operating.

Switching the device off

1. Slide the on/off switch (1) backward to 0.

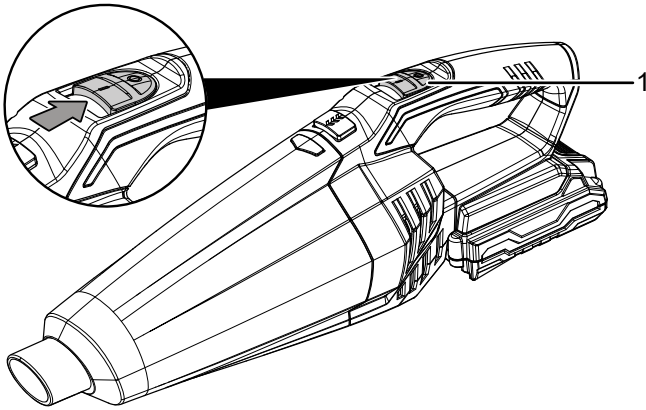

⇒ The device is switched off.

Shutdown



Warning of electrical voltage

Do not touch the mains plug with wet or damp hands.

- Switch off the device.
- Hold onto the mains plug while pulling the power cable of the charger out of the mains socket.
- Remove the battery from the device (see Start-up chapter).
- Clean the device according to the Maintenance chapter.
- Store the device according to the Transport and storage chapter.

Available accessories



Warning

Only use accessories and additional equipment specified in the operating manual. Using insertion tools or accessories other than those specified in the operating manual may cause a risk of injury.

Designation	Article number
Multiflex 20V 2.0 Ah spare battery	6.200.000.303
Multiflex 20V 4.0 Ah spare battery	6.200.000.320

Errors and faults

The device has been checked for proper functioning several times during production. If malfunctions occur nonetheless, check the device according to the following list.

Troubleshooting tasks which require the housing to be opened must only be carried out by an authorized specialist electrical company or by Trotec.

Light smoke or odour is emitted during the first use:

- This is not a fault. These phenomena disappear after a brief runtime.

The device becomes hot:

- Keep the venting slots clear to prevent the motor from overheating.



Info

Wait for at least 10 minutes before switching the device back on.

The device does not start:

- The battery power might be too low. Recharge the battery.
- Check whether the battery is correctly connected to the device.

Slide the battery onto the device in a way that the battery terminals engage. The battery must lock in place in the device.

- Check the battery terminals for dirt. Remove any dirt.

The battery does not charge:

- Check whether the battery is correctly connected to the quick charger.

Slide the battery into the quick charger in a way that the battery terminals engage in the quick charger. The battery must lock in place in the quick charger.

- Check the power connection.
- Check the power cable and mains plug for damages.
- Check the fuse (home).
- Check the quick charger for damages. Should the quick charger be damaged, stop using it. Contact the Trotec customer service.
- Check the battery terminals for dirt. Remove any dirt.
- The battery might be defective and have to be replaced. Only use batteries of the same type.



Info

Wait for at least 10 minutes before switching the device back on.

Note

Wait for at least 3 minutes after maintenance and repair work. Only then switch the device back on.

The device still does not operate correctly after these checks:

Please contact the customer service. If necessary, bring the device to an authorised specialist electrical company or to Trotec for repair.

Maintenance

Activities required before starting maintenance



Warning of electrical voltage

Do not touch the mains plug or the battery with wet or damp hands.

- Switch the device off.
- Allow the device to cool down completely.
- Remove the battery from the device.



Warning of electrical voltage

Maintenance tasks which require the housing to be opened must only be carried out by authorised specialist companies or by Trotec.

Notes on maintenance

Inside the device, there are no parts that need to be maintained or lubricated by the user.

Safety signs on the battery and the charger

Check the safety signs attached to the battery and the charger at regular intervals. Replace illegible safety signs!

Cleaning

The device should be cleaned before and after each use.



Warning of electrical voltage

There is a risk of a short-circuit due to liquids penetrating the housing!

Do not immerse the device and the accessories in water. Make sure that no water or other liquids can enter the housing.

- Clean the device with a soft, damp and lint-free cloth. Make sure that no moisture enters the housing. Protect electrical components from moisture. Do not use any aggressive cleaning agents such as cleaning sprays, solvents, alcohol-based or abrasive cleaners to dampen the cloth.
- Dry the device with a soft, lint-free cloth.
- Keep the connecting terminals on the device and charger clean.
- Keep the ventilation openings free from dust deposits to prevent overheating of the motor.



Info

Empty the collection container (5) and clean the dust filter (7) after each application to prevent a motor overload and so as not to reduce the device efficiency.

Emptying the collection container

Please proceed as follows to empty the collection container:

- ✓ The device is switched off.
- 1. Hold the device so that the collection container (5) points downwards.
- 2. To open the collection container, press the release button (8) and remove the collection container (5).

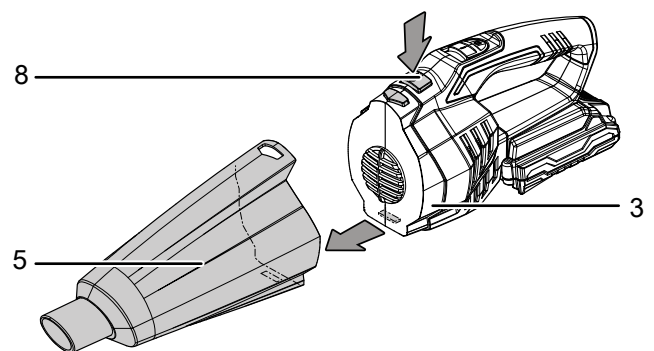

- 3. Remove the dust filter (7) from the collection container (5).
- 4. Empty the collection container (5) and rinse it with water, if necessary. Allow the collection container (5) to air-dry.
- 5. Reattach the dry collection container (5) to the motor housing (3) as described in Connecting motor housing and collection container.

Cleaning the dust filter

Please proceed as follows to clean the dust filter:

1. Remove the dust filter (7) from the collection container (5).
2. Pull the filter bag with the holding fixture (20) out of the dust filter housing (21).

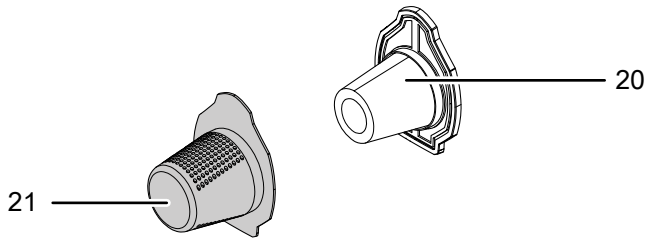

3. Remove coarse dirt and tap out the filter bag with the holding fixture (20) and the dust filter housing (21).
4. If heavily soiled, rinse the filter bag with the holding fixture (20) and the dust filter housing (21) with cold water. Allow the dust filter to air-dry. Wait until the filter bag with the holding fixture (20) and the dust filter housing (21) have completely dried before reinserting them into the collection container.
5. Insert the filter bag with the holding fixture (20) into the dust filter housing (21) as described under Connecting dust filter and collection container.
6. Reinsert the dust filter (7) into the device as described under Connecting dust filter and collection container.

Connecting dust filter and collection container

Before start-up, the dust filter needs to be reassembled and inserted in the collection container (5). To do so, please proceed as follows:

1. Connect the filter bag with the holding fixture (20) to the dust filter housing (21).

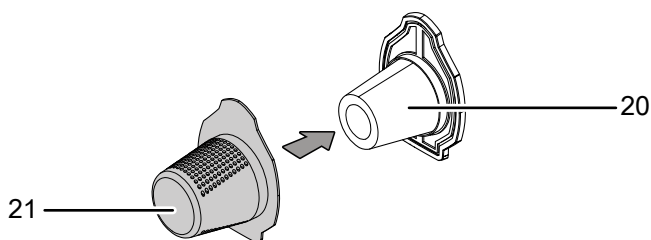

⇒ The dust filter (7) is now assembled and can be inserted in the collection container (5).

2. Slide the dust filter (7) into the collection container (5) until it is held securely by the integrated guides inside the collection container (5).

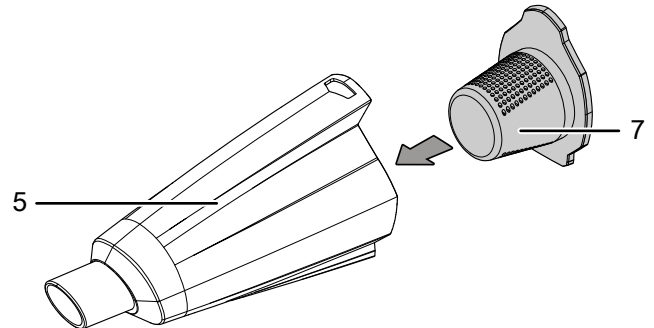

⇒ The collection container (5) may now be connected to the motor housing (3).

Connecting motor housing and collection container

Before start-up, the motor housing (3) needs to be connected to the collection container (5). To do so, please proceed as follows:

1. Fit the collection container (5) onto the motor housing (3) in a way that the recess (9) at the bottom of the collection container is seated on the tongue beneath the motor housing.
2. Slide the collection container (5) onto the motor housing (3) until the release button (8) snaps into place.

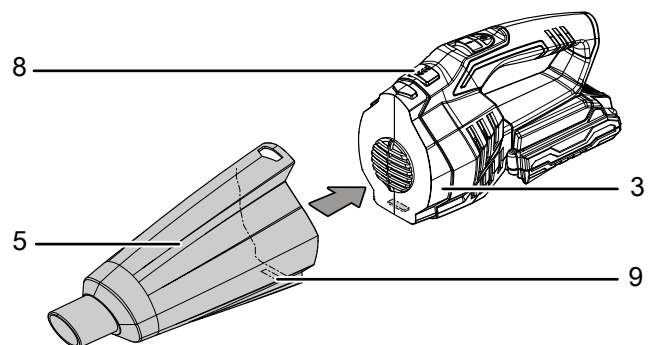

3. Check whether the collection container (5) is firmly seated on the motor housing (3).
⇒ Collection container (5) and motor housing (3) are connected.

Disposal



The icon with the crossed-out waste bin on waste electrical or electronic equipment stipulates that this equipment must not be disposed of with the household waste at the end of its life. You will find collection points for free return of waste electrical and electronic equipment in your vicinity. The addresses can be obtained from your municipality or local administration. You can also find out about other return options that apply for many EU countries on the website <https://hub.trotec.com/?id=45090>. Otherwise, please contact an official recycling centre for electronic and electrical equipment authorised for your country.

The separate collection of waste electrical and electronic equipment aims to enable the re-use, recycling and other forms of recovery of waste equipment as well as to prevent negative effects for the environment and human health caused by the disposal of hazardous substances potentially contained in the equipment.



In the European Union, batteries and accumulators must not be treated as domestic waste, but must be disposed of professionally in accordance with Directive 2006/66/EC of the European Parliament and of the Council of 6 September 2006 on batteries and accumulators. Please dispose of batteries and accumulators according to the relevant legal requirements.

Trotec GmbH

Grebener Str. 7
D-52525 Heinsberg

☎ +49 2452 962-400

☎ +49 2452 962-200

✉ info@trotec.com

www.trotec.com